



DFS
High Resolution GC/MS

Designed for **Highest Sensitivity**

Food Safety • Environmental Analysis
Doping Control • Petrochemistry

Thermo
SCIENTIFIC

Confidence in your analysis

Dependable, Powerful, P

The Thermo Scientific DFS is the most advanced magnetic sector, high resolution mass spectrometer ever built for target compound analysis and for solving general organic analytical questions.

The DFS GC/HRMS delivers

- Highest performance and lowest signal/noise
- Dependable productivity from modern design
- Innovative design for impressive results

The DFS removes GC/HRMS complexity

- Automated tuning and intuitive user interface
- Eliminate daily calibration routines with automated MID mass calibration
- Simplified control of complex GC configurations

The DFS is economical ...

- Thrifty – uses half the power of the nearest competitor
- Quiet – pumps housed inside instrument
- Small – preserves your valuable laboratory real estate

... and it is versatile

- Application flexibility – two GCs and up to four GC columns
- Multiple ionisation choices – EI, CI, CI-, FAB, FI & FD
- Multiple probe options – DIP, DCI, HTDCI, FD



productive



Achieve your results

Full application flexibility

The DFS can be used for any of your GC/MS applications that demand sensitivity and matrix tolerance.

A gold standard in confident, ultra-trace, quantification; the DFS brings you proven productivity. Your DFS gives unrivalled dimensions in flexibility and can deliver a range applications on a single platform in one analytical sequence.

Whether you need to investigate or quantitate; the DFS delivers you a complete hardware and software solution.

Industrial Chemicals

- Unknown characterization
- Structure confirmation and identification

Doping Control

- Steroids and Growth Promoters

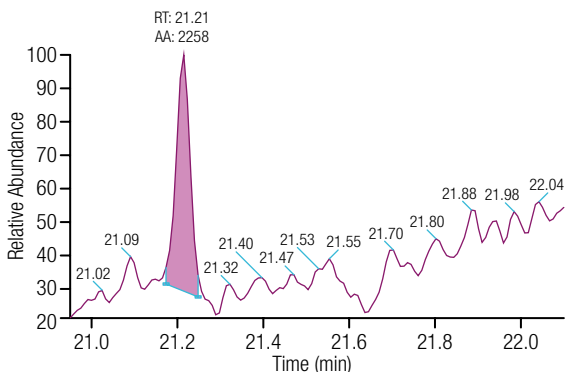

Figure 1: NCI MID of banned pesticide Tolyfluanid in fruit (circa 25 fg on column)

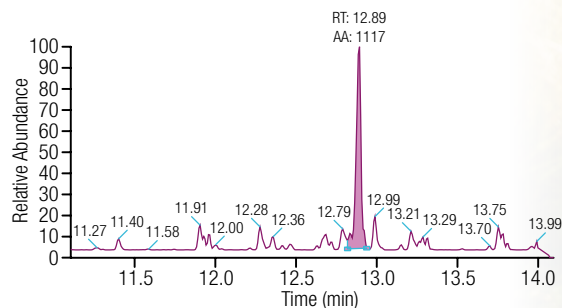
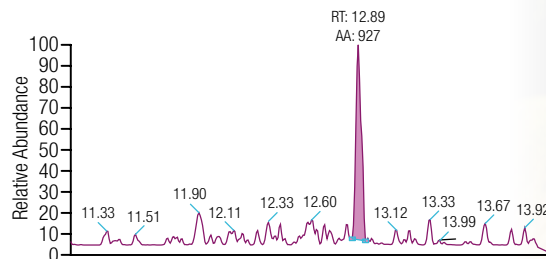

Figure 3: MID of carcinogen 2378-TCDD in milk (circa 20 fg on column)

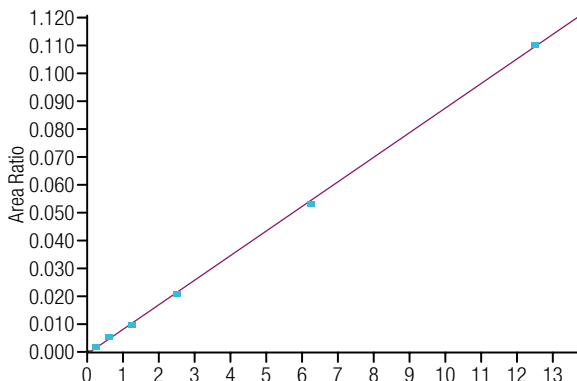

Figure 2: Calibration curve for Tolyfluanid in NCI mode.

Food Safety & Environmental

- Pesticides - EPA 1699
- Dioxins - EN 1948, EPA 8290, EPA 1613, JIS K 0311/0312
- PCBs - EPA 1668
- BFRs - EPA 1614
- PAHs
- Hormones - EPA1698

Petrochemicals

- Distillate characterization
- Bio-markers and metabolites



Experience a new dimension

The revolutionary ion optics and the intuitive user interface make operation of the instrument easy and straightforward.

Novel Analyzer

The magnetic sector analyzer is the first in class with virtually no image aberrations. It is perfectly double focusing, employing an ultra high precision toroidal electrostatic analyzer and a carefully refined magnetic analyzer. This directly translates into stability and ruggedness.

- Tuning for highest sensitivity does not influence the preset resolution
- Fully automatic ion source tuning
- Automatic setting of mass resolution
- No tuning required for other ion optical elements
- Mass calibration completely independent from any scan or tuning parameter
- Single universal mass calibration for all modes of operation

The DFS GC/HRMS ion optics are forgiving and robust while delivering the highest sensitivity and selectivity.

Ion Source

The ion source has been designed with special emphasis on sensitivity, durability and ease of maintenance. Low maintenance and short downtime increase productivity.

- Exchange of inner ion volume and filament without venting
- Ion volume manufactured from inert stainless steel alloy for maximum robustness
- Plug-in outer ion source for easy maintenance
- Optimized long lifetime filaments for EI and CI
- New easy-to-use, high stability reference inlet system

Electronics

The DFS system has completely new, state-of-the-art electronics. It uses dedicated micro-controllers on all boards, enabling efficient and fast computer control and read-back of all important parameters and voltages through a common interconnect bus. The magnetic field regulator is fast and stable, yet very energy efficient, utilizing 'power-on-demand' switching power supplies. It fully complies with the EU power factor correction directive. The magnetic field is controlled with 20 bit digital resolution and receives its feedback from a magnetic field probe (as standard), supporting the single universal mass calibration.

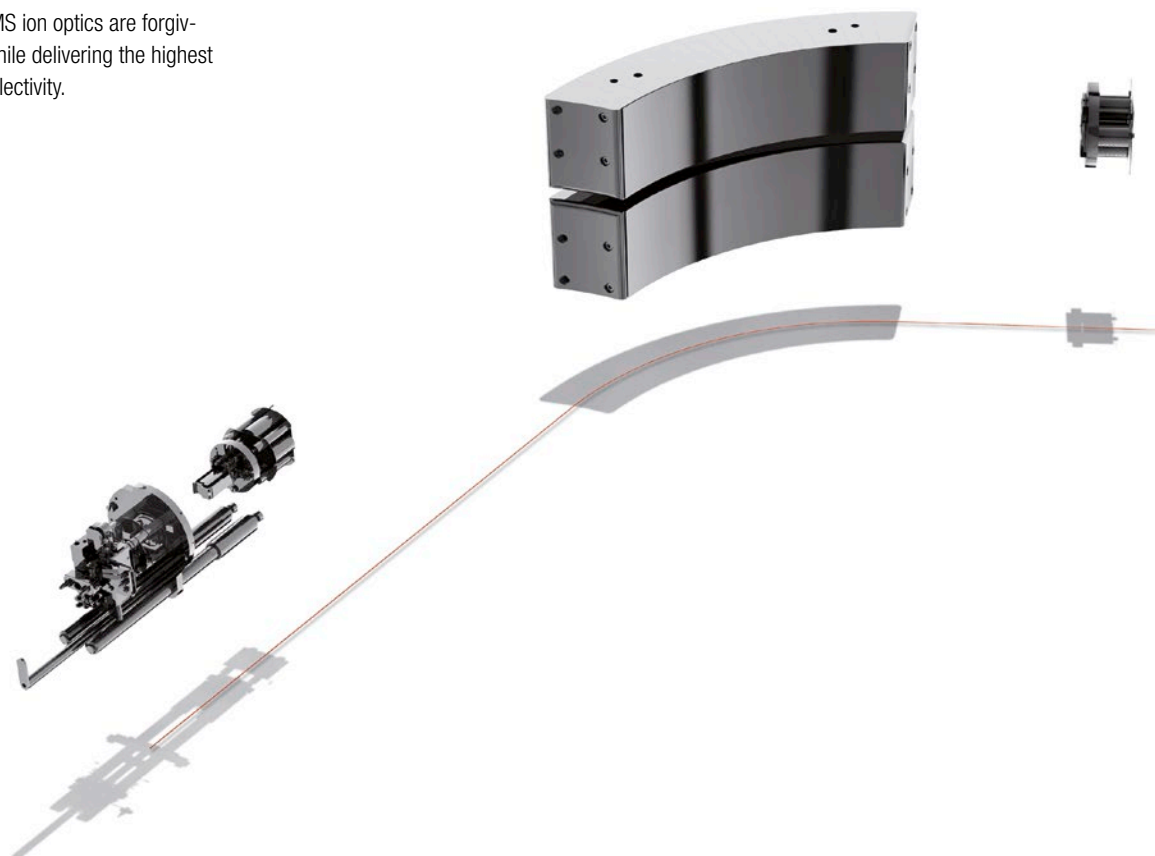

Several new technologies have been incorporated into this revolutionary mass spectrometer to provide the most powerful GC/HRMS ever designed.

Chassis and Cabinet

The small-footprint cabinet contains the analyzer, electronics, and the complete pumping system, including roughing pumps. Its ingenious design allows the DFS GC/HRMS to be shipped completely assembled with the magnet in place, resulting in short installation times. No need for a crane, and you have the security that the system arrives exactly the way it has been tested in the factory. Modern design means the DFS weighs less than conventional magnetic sector instruments, thus minimizing the demands on the laboratory environment.

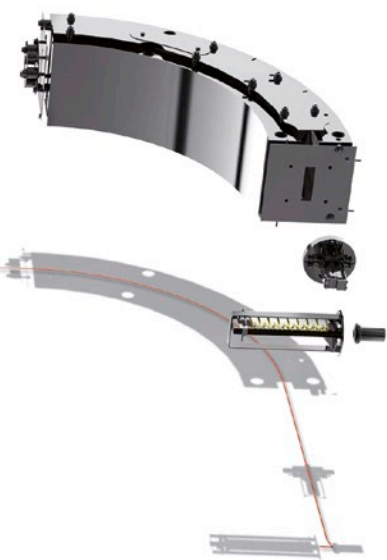

Tune Software

The DFS uses Thermo Scientific TunePlus software for data acquisition. This is the same user interface for quadrupole, ion trap and triple quadrupole MS systems.

The same simple user interface concept has been extended to the DFS; making tuning, experiment and sequence set-up intuitive and rapid.

GC/MS Productivity

The DFS system delivers unprecedented flexibility and productivity for large sample series. It can be optionally equipped with two Thermo Scientific Trace 1310 GCs. The two GCs are simultaneously installed into the ion source. This allows separation and analysis on two independent GC setups.

It is a system designed for unattended operation, in which the Thermo Scientific TriPlus RSH autosampler offers highest sample capacity and ultimate sampling flexibility while serving one or two Trace 1310 GC units from shared sample trays.

Features and Capabilities

- Mass range of 2-6000 Da
- Scan speeds continuously variable from 0.1-10,000 sec/decade
- Removable ion volumes for easy source maintenance
- Radially laminated magnet
- Field based calibration, i.e. mass calibration is independent of scan speed, polarity, ionization mode
- High performance toroidal ESA
- Detection system with ± 20 kV conversion dynode and long-life secondary electron multiplier for efficient detection of ions
- Full range of ionization modes available
- Pneumatically actuated exchange lock for ventless exchange of ionization volumes
- Water cooled DI probe and DCI probe available
- Ultra low detection limits for POPs
- Going Green - best of its class for power consumption, water cooling and air conditioning
- Modern Windows 7 operating system for simple network integration and OS maintenance

Tools for your success

Thermo Scientific Software

One intuitive platform for GC/MS, LC/MS, and Advanced MS instruments provides confident control, from method development to reporting.

Xcalibur Software

Xcalibur™ is an advanced chromatographic data system, delivering a unique combination of functionality, system control, and ease of use. The software is designed to simplify your daily analytical tasks. This powerful simplicity combined with the advanced features of the Microsoft® Windows® 7 operating system and Microsoft Office productivity tools provides a system solution that is second to none.

The DFS GC/HRMS generates high quality data regardless of matrix and concentration, low or high resolution, scanning or MID data. The enormous amount of information hidden in the data can be revealed using the built-in features. The Xcalibur software provides complete control of the DFS system, the Trace 1310 GC and the TriPlus RSH auto-sampler, as well as other devices.

It contains a built-in audit trail to ensure compliance with your laboratory's SOPs and quality programs. Generating reports from your data has never been easier than with XReport, which provides a flexible visual interface for intuitive report template creation and report generation. Simple drop-down menus and drag-and-drop objects provide complete flexibility for your reporting needs.

Xcalibur seamlessly integrates layered applications, including;

- Quantification software such as TraceFinder and TargetQuan 3.
- Investigative software such as Thermo Scientific Mass Frontier software which simplifies interpretation of mass spectra
- Reference libraries from NIST, Wiley and Maurer Pfleger Weber

TargetQuan 3: Simple customizable tabbed layouts

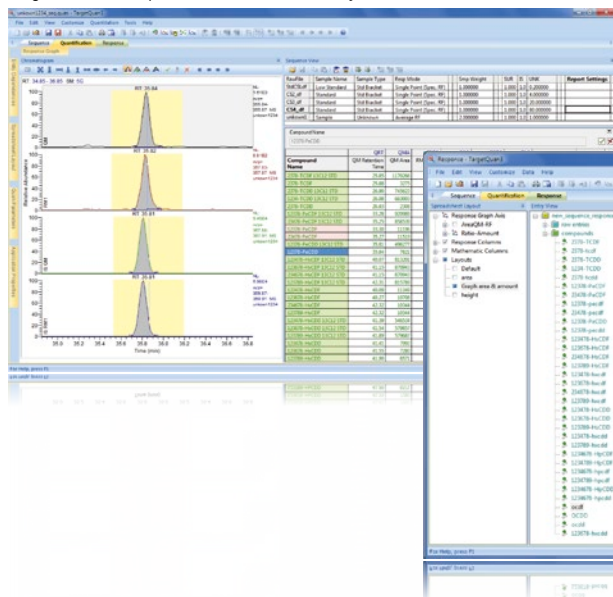

TargetQuan 3: Response curve

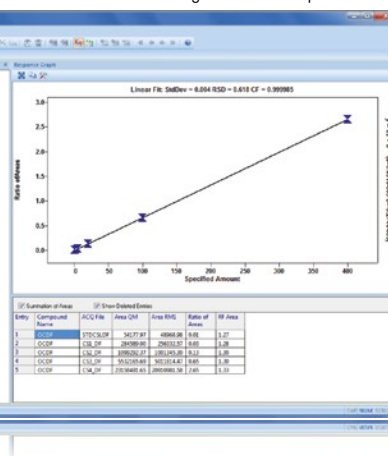

Thermo Scientific TargetQuan 3 software is uniquely tailored for a workflow-orientated POPs quantification. This software package is designed specifically to serve laboratories charged with performing routine quantification of POPs in a regulated environment.

TargetQuan 3 Software

TargetQuan 3 has a simplified workflow for efficient data processing:

- Import Xcalibur sequences for batch processing and automatically integrate peaks, generate response curves and quantify data
- Process entire batches through new sequence tab function

Designed specifically for POPs quantification, TargetQuan 3 contains all of the advanced calculations and factors demanded by this application:

- Quantification, based on relative response factors (RRF) and single or averaged response can be applied independently to analytes and samples
- Incorporation of Toxic Equivalence Factors (TEFs) to automatically calculate Toxic Equivalent Quotient (TEQ)
- Flagging and reporting of QC parameters such as out-of-range ion ratios and RT shift
- Totals calculations can be performed from all groups as well as EU Upper/lower bound calculations

TargetQuan 3 enables you to achieve regulatory conformity and reporting confidence with its comprehensive QA/QC checks and measures to satisfy international protocols such as:

- US EPA 1613b, 1668b, 1614, 8290, Method 23
- Japan JIS K 0311/0312
- Europe EN 1948
- Commission Directive 2002/70/EC
- Council Directive 96/23/EC

The versatility of TargetQuan 3 allows the user experience to be personalized and productive:

- Fully customizable screen layouts to view your data in the way you want
- Tabbed views for quick navigation
- Define printed or electronic reports including options to print or automatically export calculated values and chromatograms
- Custom calculations provide the flexibility to fully customize your results
- Platform independence to handle MS, MS/MS and HRMS data on a single software with 'site' license option flexibility

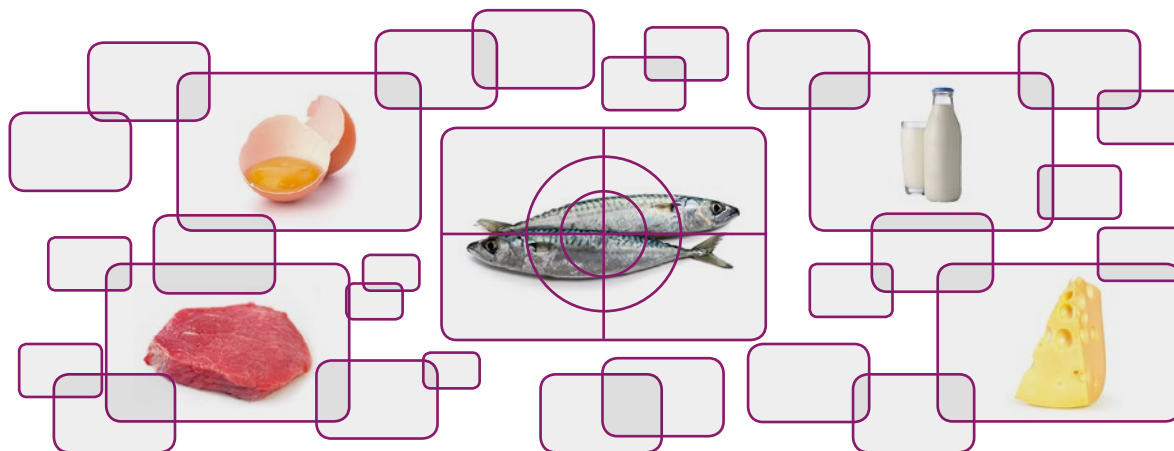

Excellence in GC-MS begins with the GC

Your problems of the past, need not be the problems of the future. Reduce preparation errors. Run sequences longer than before. Change syringes on the fly. Transfer methods without requiring re-optimisation. The innovative Trace 1310 GC and TriPlus RSH bring solutions like no GC or auto-sampler before.

Ground-breaking Instant Connect Modularity

Tailor the Thermo Scientific TRACE 1310 GC to your needs with its proprietary user-exchangeable instant connect injector and detector modules. Swapping modules is easily done by the removal of three screws, accessible from the top of the GC. The entire process takes less than two minutes. This enables budget-conscious laboratories to expand their capabilities to accommodate new application and throughput demands. With the TRACE™ 1310 GC paired with your DFS, tomorrow's opportunity is in your hands today.

Less is More

The oven, injectors, and detectors of the TRACE 1310 GC have a very low thermal mass. This enables faster heat-up and cool-down times, reducing your inject-to-inject time and increasing your sample throughput. A completely new range of micro-volume GC detectors increases sensitivity and reduces required sample amounts and re-concentration requirements.

Easy Operation, Easy Maintenance

The TRACE 1310 GC offers an intuitive, icon-based touch screen interface which allows for local control of the GC. In addition, tool-free access to septa and liners allows for quick routine maintenance. When more aggressive injector cleaning is needed, easy removal of the entire injector body allows for sonication in solvent. Finally, two easily accessible carbon traps ensure the injector and flow lines stay clean. Combined, these new features on the TRACE 1310 GC make it the most serviceable GC in the world.

Let the robot do the work

The Thermo Scientific TriPlus RSH auto-sampler features exceptional precision, flexibility, and productivity in robotic sample handling solutions. The TriPlus RSH enables automated functionality beyond traditional liquid, headspace, and solid-phase microextraction (SPME) injections; including, standard preparation, spiking, derivatising, dilutions, mixing, heating and cooling. Ground-breaking Automatic Tool Change (ATC) gives seamless operation by automating the exchange of syringes for different tasks in a single, unattended sequence prior to sample injection. Vial Bottom Sensing allows multiple injections from a volume as low as 5 µL in a vial. Designed to provide exceptional repeatability and reliability, the TriPlus RSH auto-sampler ensures high quality analytical results, reducing human error and staff time.



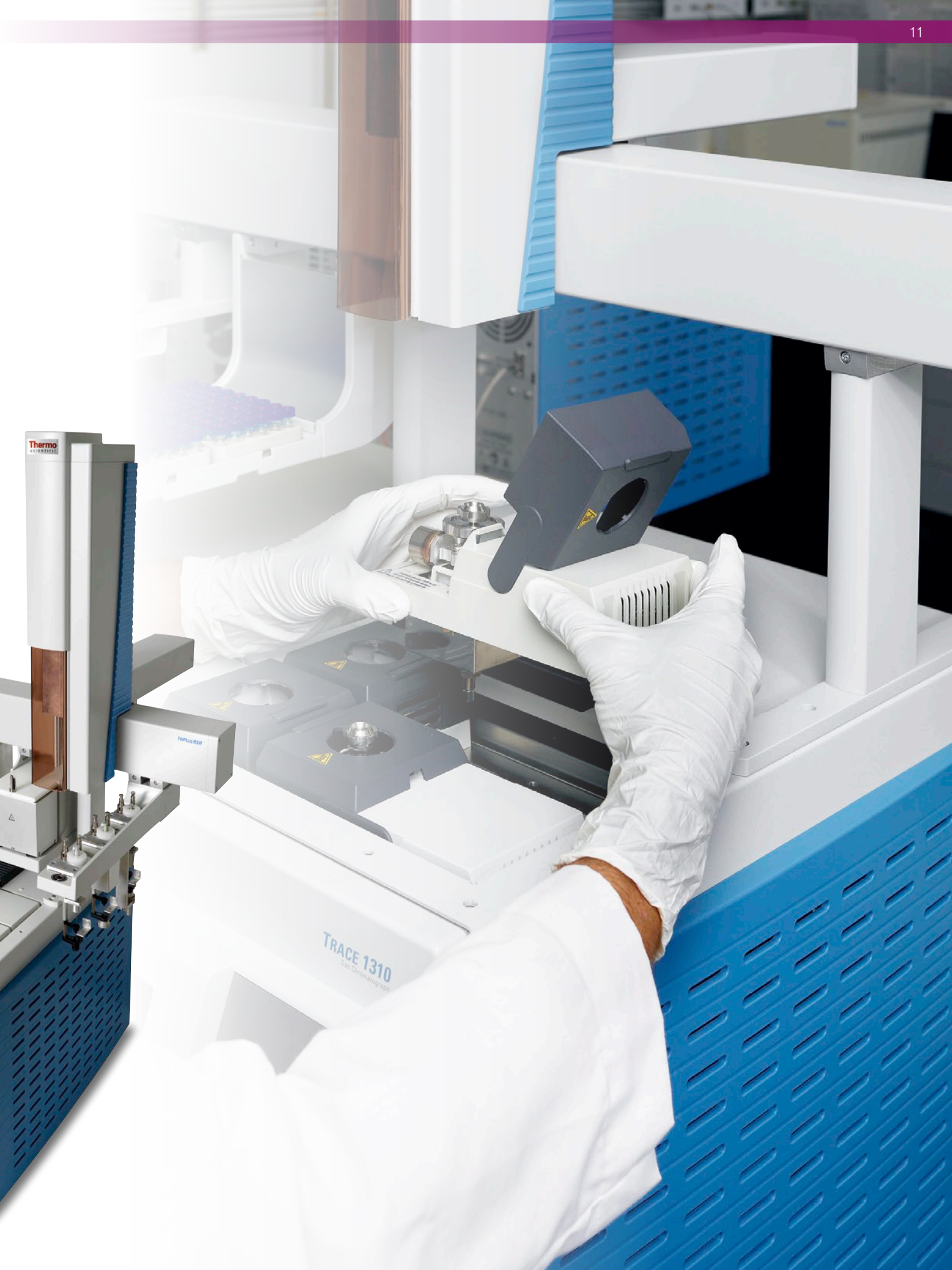

Thermo
LABTECH

TRAP+RSW

TRACE 1310
Gas Chromatograph

POPs Center of Excellence

for Food, Feed and Environmental Analysis



Dedicated Resources

To demonstrate our commitment to supporting laboratories charged with the task of researching and monitoring POPs, we have established a POPs Center of Excellence. This direct resource for our customers and associates is staffed with experts in POPs analysis. Our commitment ensures high productivity, added- value-solutions for some of the most challenging POPs determinations.

Located in Bremen, Germany, the POPs Center of Excellence is chartered to support our international customers and associates, addressing a wide range of requirements.

- Reference for POPs analysis
- Point for access to POPs methodology on Thermo Scientific products
- Resource for collaborative projects on the latest instrumentation
- Knowledge hub for Thermo Scientific product users who are working in POPs analysis
- Partner to industrial and governmental laboratories; improving quality and efficiency in our world-wide POPs monitoring capacity

For more info about the integrated POPs workflow visit



www.thermoscientific.com/POPs

www.thermoscientific.com/DFS

© 2005-2012 Thermo Fisher Scientific Inc. All rights reserved. Windows is a trademark of Microsoft Corporation. All other trademarks are the property of Thermo Fisher Scientific Inc. and its subsidiaries. This information is presented as an example of the capabilities of Thermo Fisher Scientific Inc. products. It is not intended to encourage use of these products in any manners that might infringe the intellectual property rights of others. Specifications, terms and pricing are subject to change. Not all products are available in all countries. Please consult your local sales representative for details.



Thermo Fisher Scientific (Bremen) GmbH
Management System Registered to ISO 9001:2008

Africa-Other +27 11 570 1840
Australia +61 2 8844 9500
Austria +43 1 333 50 34 0
Belgium +32 53 73 42 41
Canada +1 800 530 8447
China +86 10 8419 3588
Denmark +45 70 23 62 60
Europe-Other +43 1 333 50 34 0

Finland /Norway/Sweden
+46 8 556 468 00
France +33 1 60 92 48 00
Germany +49 6103 408 1014
India +91 22 6742 9434
Italy +39 02 950 591
Japan +81 45 453 9100
Latin America +1 608 276 5659

Middle East +43 1 333 50 34 0
Netherlands +31 76 579 55 55
South Africa +27 11 570 1840
Spain +34 914 845 965
Switzerland +41 61 716 77 00
UK +44 1442 233555
USA +1 800 532 4752

Thermo
SCIENTIFIC

Part of Thermo Fisher Scientific